

Railway turning

Re-turning and new wheel turning

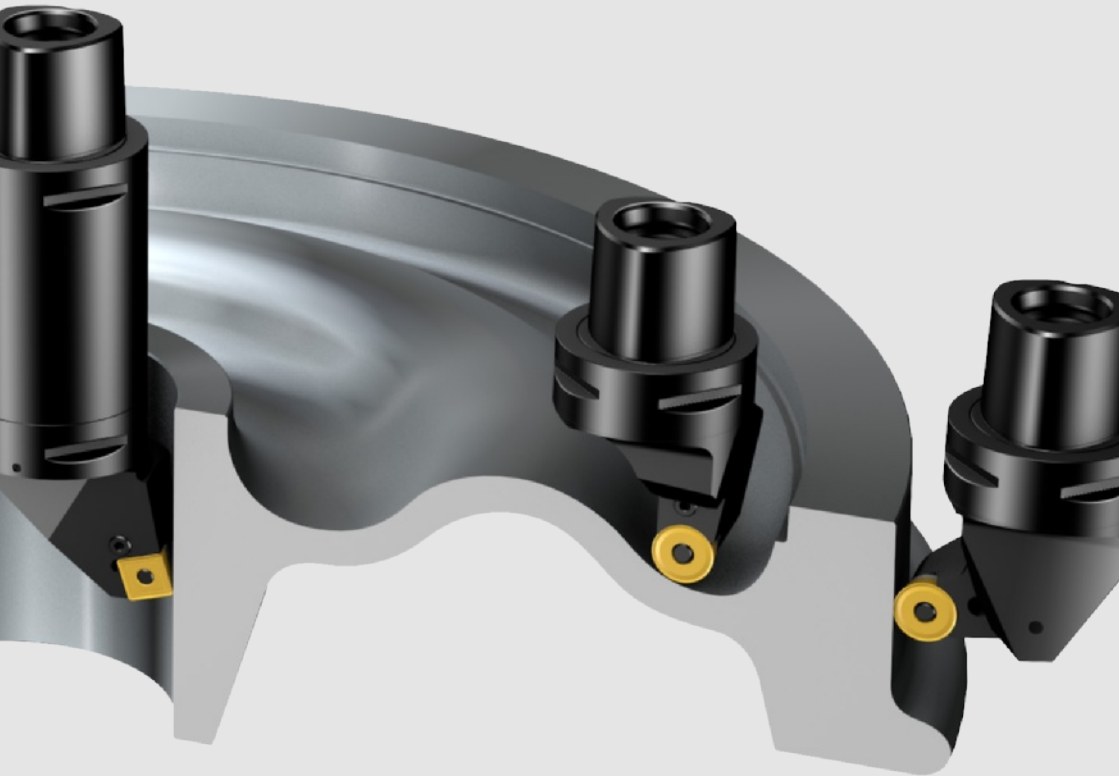

CONTENTS

INTRODUCTION	4
Different train types	5
Wheel material	6
Wheel dimensions	7
Wheel shapes	7
The wheel manufacturing process	8
NEW WHEEL TURNING	10
Initial considerations	10
Machine types	10
Product and wheel overview	12
Situation analysis	15
Best practice	17
Troubleshooting	22
RE-TURNING RAILWAY WHEELS	27
Initial considerations	27
Machine types	29
Product and wheel overview	34
Situation analysis	37
Best practice	41
Troubleshooting	48

INTRODUCTION

Railway wheel turning is about machining large components in big machines, with large depths of cut. Depending on train type the wheels have their different characteristics and requirements. Within new wheel turning there are tool holders featuring over and under coolant and reliable inserts for complete machining of any railway wheel. In the area of re-turning you find shanks and inserts that securely machines the old wheels to be as good as new.



To achieve the best possible result there are different considerations to be made. The guide contains two different chapters where the first one covers turning of new wheels and the following re-turning of wheels with tools from Sandvik Coromant. The chapters include a product and wheel feature overview, situation analysis, best practice recommendations and troubleshooting advices for the most common situations.

Overview

Situation
analysis

Best
practice

Troubleshooting

Different train types

This application guide will focus on the three main train types; freight, metro and high speed trains. These three train categories all have their different characteristics and wheel requirements in terms of dimensions, profiles, tolerances and type of material.



FREIGHT

The trains are heavy, hence the wear (typically overrolled material, high flanges, holes and flat spots) on the wheels is high. Tolerances are less important. Brake marks from cargo cars very often appear on the outer diameter of the wheels.



METRO

Wheels are small in diameter, some have rubber layers between the outer diameter of the wheel and hub to minimize noise. The trains are light and there are separated brake discs on the trains.



HIGH SPEED

High speed trains feature the largest wheels and have high demands on exact wheel dimensions as it is directly related to the comfort for the passenger. To ensure that the wheels are balanced, the tolerances on the outer diameters are high. Hence, high speed trains are re-turned quite often.

Wheel material

The basic material is unalloyed and alloyed steel, although there are different material standards and nominations in the different markets. When it comes to railway wheels, the majority (95%) are made of rolled steel, but a small amount is also made of cast steel.

Material standards can be found describing hardnesses from ER1 to ER9. Most common are standards from ER6-ER9.

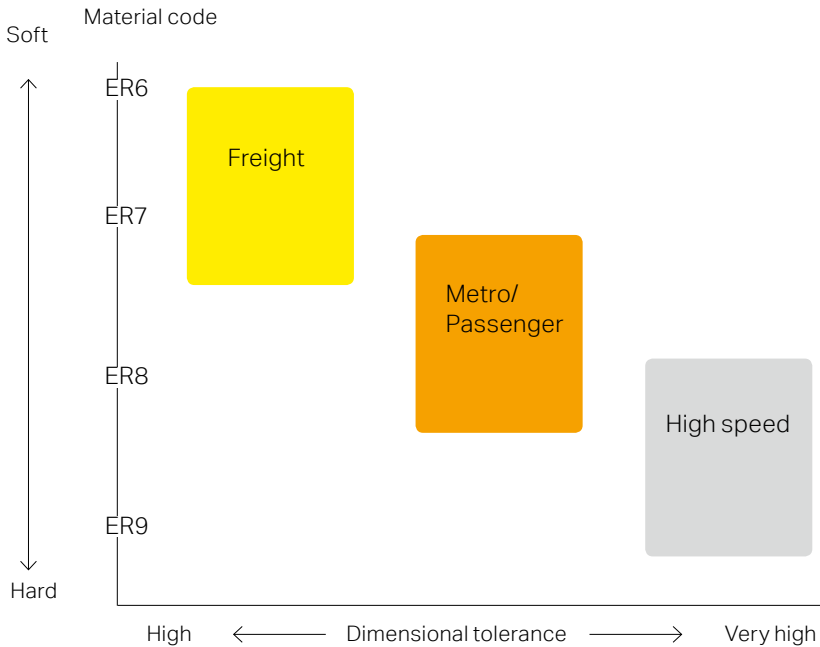

Wheel dimensions

Different train types have different types of wheels, the diameter ranges between approximately 400-1200 mm:

- Metro: 400 to 650 mm (15.7 to 25.6 inch)
- Freight: 800 to 900 mm (31.5 to 35.4 inch)
- High speed: between 900 and 1200 mm (35.4 to 47.2 inch)

Note: Machining wheels with smaller diameters demands smaller inserts. This to avoid long cutting edge engagements which leads to high cutting forces.

Wheel shapes

The shape of the wheels can be waved or straight. The different shapes can be seen on all kind of trains and wagons but the straight shape is more common on locomotives and metro trains as the space for wheels and brake systems is limited. The waved shape is more common on wagons. The type of shape depends on the wheel size, the way of use and whether it is wagons, locomotives or wheels featuring grooves for noise reduction etc.

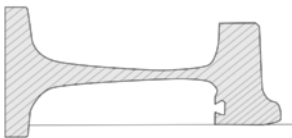

Straight wheel shape: typically found on locomotives and metro trains.



Waved wheel shape: typically found on wagons.

The wheel manufacturing process

The picture illustrates an example of how a railway wheel is manufactured.

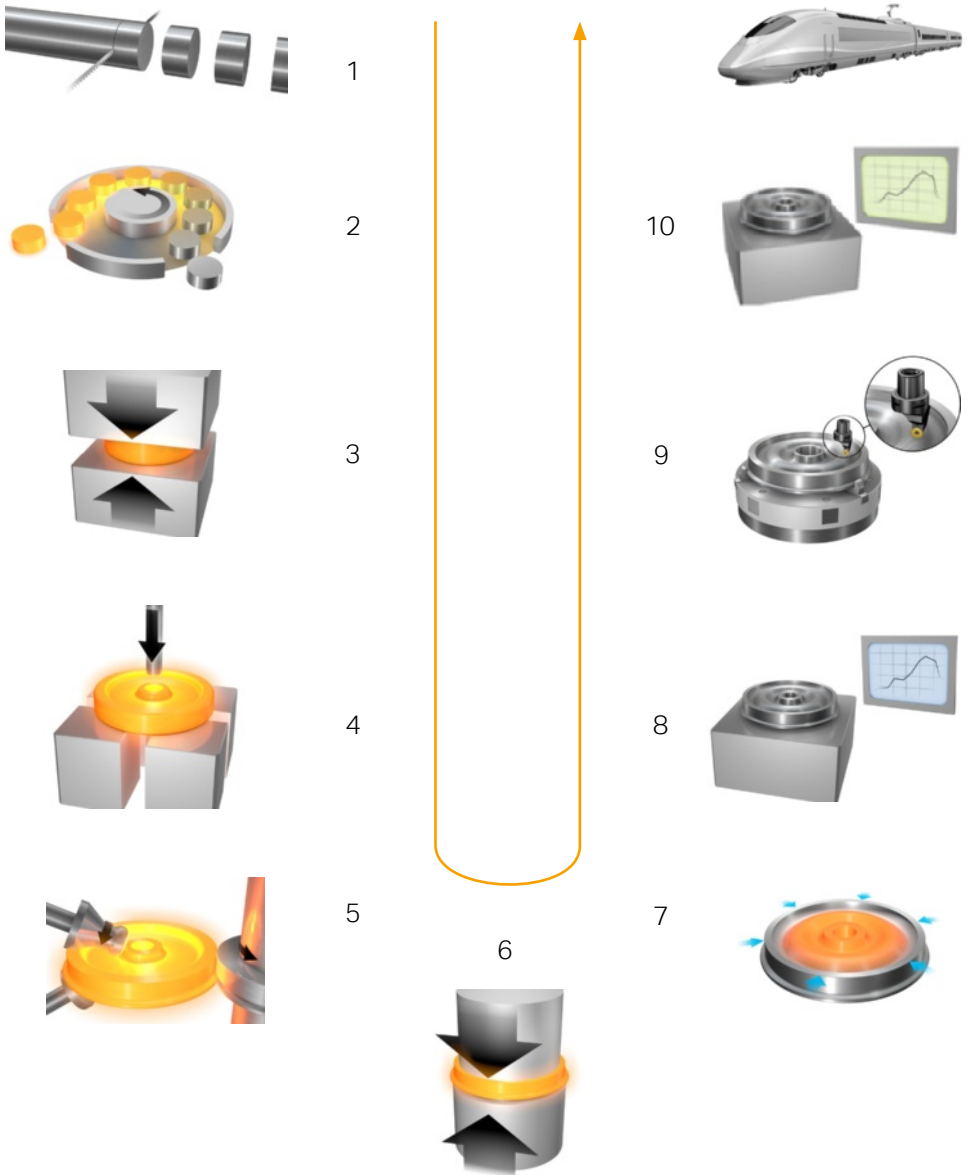

1. Parting blanks
2. Heating of blanks in rotary kiln
3. Compression forging
4. Hole punching process
5. Roll forming
6. Bending process
7. Hardening process – cooling with water
8. Mechanical testing
9. Turning of wheel
10. Non-destructive test (ultrasonic testing to detect e.g. eventual cracks)

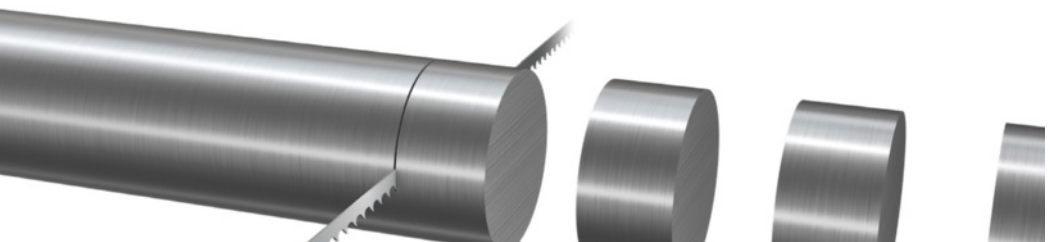



A vertical turning

NEW WHEEL TURNING

Initial considerations

Before starting to machine a wheel, there are different factors to consider regarding component and machine:

- Which profile to machine (e.g. narrow profile requires smaller inserts than a wide profile)
- Hardness and surface quality of the component
- Overhang - long overhang requires more tool stability
- Coolant supply or dry machining
- Stability, machine power, torque and clamping

Machine types

New railway wheels are machined in vertical lathes. It might vary between 1 or 2 turrets, but the tool set-up is always basically the same. In new machines you can expect wet machining but for older models dry is more common.

MODERN MACHINES

- For machining wheel diameters up to 1200mm (47.2 inch)
- Power for double turret or RAM is ~150 kW
- Tool holders: Coromant Capto® C10 or 5050 shanks
- Inserts: often 32 round inserts
- Machines are loaded by robots, and max RPM is about 150 to 200min
- Clamping: One clamping for the raw wheel, with "claws" and a second clamping for the finished wheel after first operation



OLDER MACHINES

- For machining wheel diameters up to 1200mm (47.2 inch)
- Normally only one turret, meaning less power needed approximately 60kW
- Tools in use: Frequently re-build for tool holders with Coromant Capto® interface or shanks, often with 32 round inserts
- Pure machining, loud, hot and dusty
- The machine is open, meaning chips flies out during operation
- Less power: machining with low speeds, low feeds and smaller inserts



OTHER CONCEPTS

- Pick-up machines
- New type of machine with one or two turrets
- Wheels picked up from main spindle, tools working from underneath

Product and wheel overview

Here you find Sandvik Coromant's product offer and what tools to use when turning a new railway wheel.

WHEEL FEATURES

The wheel is divided into three areas:

1. The rim: includes machining the contact surface and facing the outside of the wheel.
2. The web: is the part to machine between hub and rim.
3. The hub: includes machining the bore, but also facing the outside of the wheel.

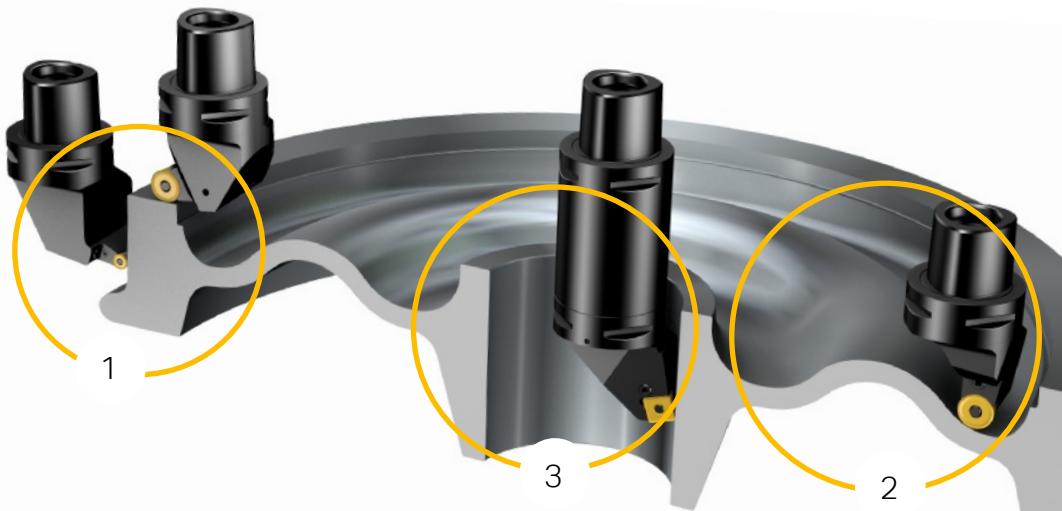

PRODUCT OVERVIEW

T-Max P tool holders

The T-Max P holders offer stable clamping and are available with high precision over- and under coolant and Coromant Capto® interface, optimized for machining new railway wheels.

Inserts

Round and square inserts are available in different grades and geometry types. Together with the tool holders there is a standard offer for complete machining of a railway wheel.

Tool holding



- Coromant Capto, size 10
- Shank tools
- Over- and under coolant as option

Insert

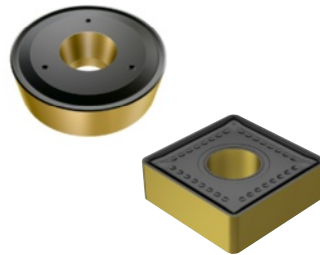

- Round inserts size 32 mm
- Square inserts size 25 mm
- Geometries for roughing and finishing



Note: Remember to always look for the latest assortment on our website www.sandvik.coromant.com. Special offer for railway turning is available, for more information contact your local Sandvik Coromant representative.

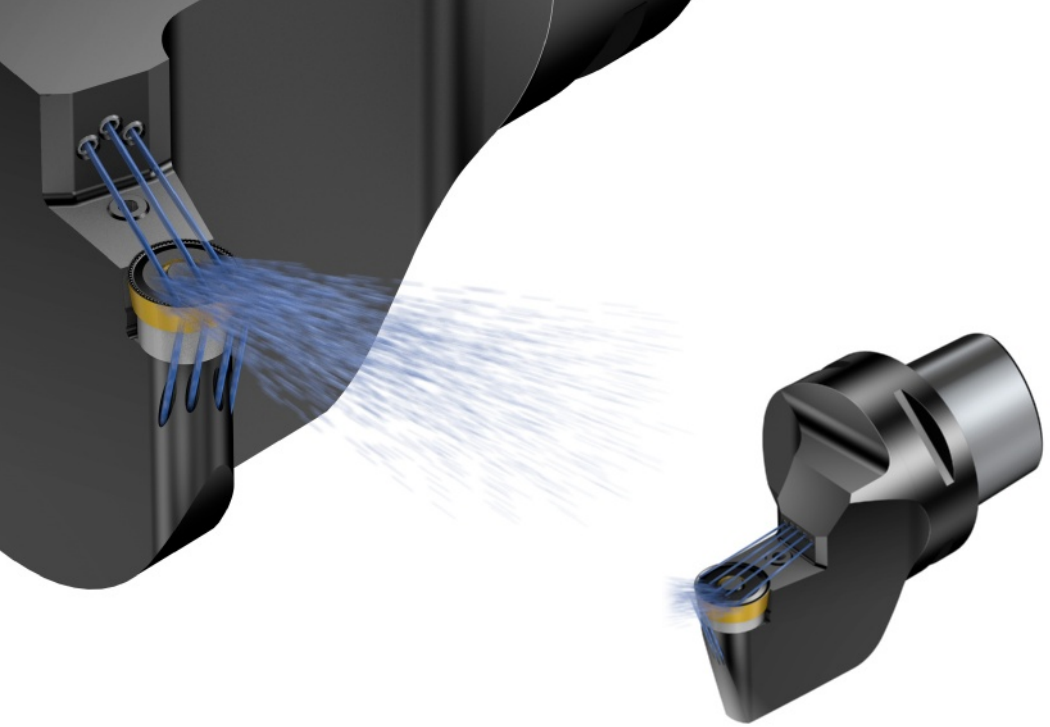

HIGH PRECISION COOLANT

All the new tool holders are equipped with high precision nozzles and offer both over and under coolant.

- The effects of high precision coolant: Coolant delivered to the right spot at the cutting zone has a large impact on chip control and tool life for improved process security.
- The effects of under coolant: When machining at the same cutting data enables an increase of tool life by 67% and helps against the negative effect of thermal cracks.

Situation analysis

The main purpose with the situation analysis is to ensure we have stability for best process security. Use the checklist as follows.

In addition, always identify the challenges and limitations in dialogue with the customer and explain how establishing a routine for tool maintenance in the work shop will prevent problems.



CHECKLIST FOR SITUATION ANALYSIS

1. Check the clamping of the wheel
 - The clamping is on the outer part of the wheel, meaning it is a big distance between the clamping points. If vibration – this can be the reason
 - Smaller wheel dimensions – the wheel itself is more stable. Large dimensions – the risk for vibration is high
 - Compare the difference when putting a force between 400 mm compared to 1200 mm
 - From 950 mm (37.4 inch) – normally some kind of support is needed
 - Cutting data needs to be modified (feed and speed)

2. Check the tool holder
 - For best stability the clamping overhang should be as short as possible
 - Check shim, lever clamping, insert pocket and insert if worn out or damaged
 - If needed, increase the size of the shank
 - Check tip seat - look for plastic deformation, if this part is damaged, a new holder is the only alternative
3. Check coolant supply
 - If machine has coolant, make sure the coolant is directed correctly
 - The coolant needs to be clean (filtered) if the tool has nozzles
4. Check the wheel
 - Check the quality of the raw material
 - If uneven hardness, mistakes from the rolling of the wheel risks affecting tool life negatively

Best practice

In this chapter you find the best practice for how to turn a 900 mm (35.4 inch) railway wheel made of rolled steel. The machining of the wheel is made in the same machine, in two placements performed in four series, using Sandvik Coromant standard tools.

Wheel type: 900 mm (35.4 inch)

Material: Rolled steel

Machining conditions: Good

1. Machining the rim

ROUGHING OPERATION

In this roughing operation of the rim profile, the machining of the flange and the contact surface is made in one cut.

Tools in use

- Tool holder: C10-PRDCL-35134-32
- Insert: RCMX 320900

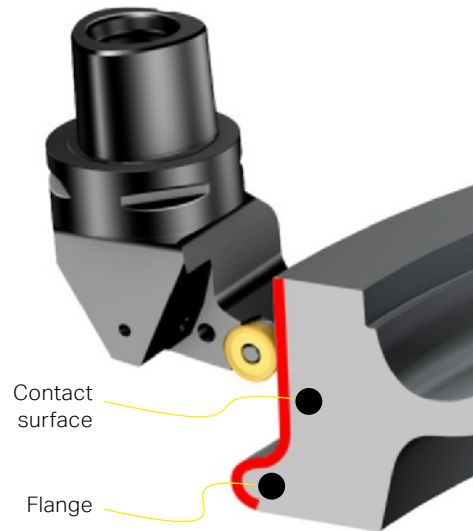

Cutting data

Operation	v_c m/min (ft/min)	f_n mm/rev (in/min)
Contact surface	90 (295)	1.2 (0.047)
Flange	90 (295)	1.4 (0.06)

FINISHING OPERATION

Before flipping the wheel, finishing operation of the contact surface is performed.

Tools in use

- Tool holder: C10-PRSCCL-70130-16
- Insert: RCMX 160900

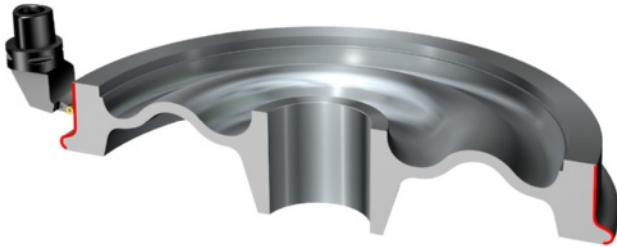

Cutting data

Operation	v_c m/min (ft/min)	f_n mm/rev (in/min)
Contact surface	100 (328)	1.25 (0.05)

Note: Preferably also the roughing/ finishing operation of the bore is made in this set-up to keep the tolerances (to secure that the bore is centred).

2. Machining the web

In this operation, the A operation lasts longer and is the "leading tool". When A tool is machining the outer diameter of the web (A1) the B tool is facing the hub (B2) at the same time. When A makes its second cut (A2), the B tool is facing the rim (B1).

When machining the web (A) it is important to get good surface quality while at the same time remove correct amount of material. You could say it is a roughing and finishing operation at the same time.

FINISHING OPERATION

1. A is the leading tool and machines the web

Tools in use

- Tool holder: C10-PRDCL-35134-32
- Insert: RCMX 320900

2. The same tool holder and insert is applied for both facing of the rim and the hub

Tools in use

- Tool holder: C10-PRDCL-35134-32
- Insert: RCMX 320900

Note: For operation A, increase the cutting speed when machining the part closest to the hub (A2) and depending on the shape of the profile, the feed also (if concave, decrease feed and if convex, increase feed).

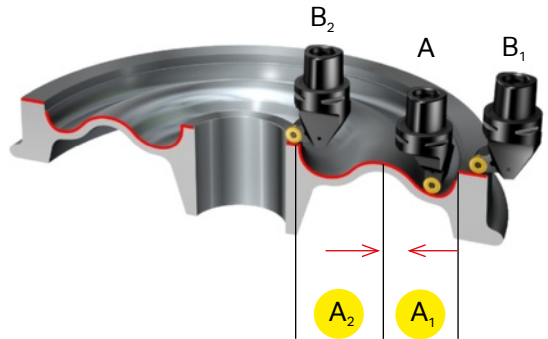

Cutting data

Operation	v_c m/min (ft/min)	f_n mm/rev (in/min)
A. Web	100 (328)	0.8-1.4 (0.031-0.055)
B. Rim, facing	100 (328)	1.4 (0.055)
C. Hub, facing	35 (115)	1.5 (0.059)

The wheel is flipped vertically, and the same tools and cutting data is applied as when machining the opposite side.

- Also here it is important to achieve correct thickness of the wheel and at the same time good surface finish
- The two operations are in sequence after each other, starting with operation A1, the leading tool

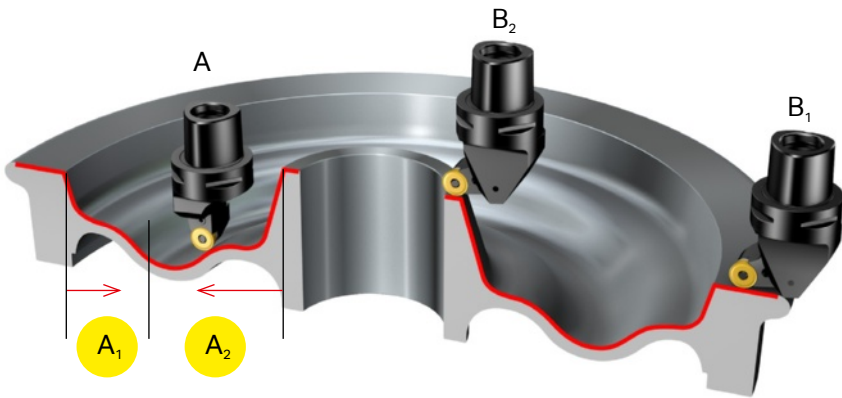

3. Machining the hub

When turning the wheel, the last stage is the machining of the hub.

ROUGHING OPERATION

Depending on amount of stock you might need to make it in two cuts, but in this case we make the whole machining in one cut.

Tools in use

- Tool holder: C10-PSKNR-68110-25
- Adaptor: C10-391.01-100 140
- Insert: SNMM 250724

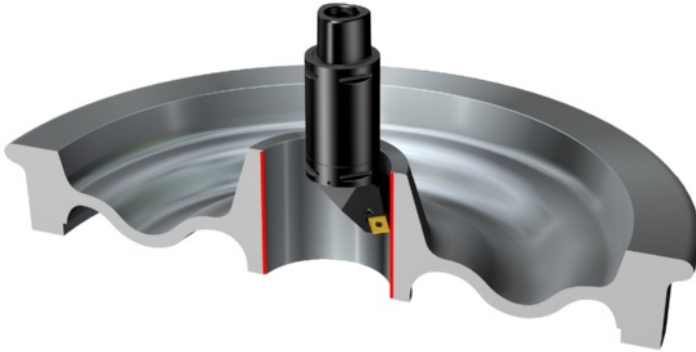

Cutting data

Operation	v_c m/min (ft/min)	f_n mm/rev (in/min)
A. Inner hub	115 (377)	1.2 (0.047)

Note: After the roughing operation one groove is made inside the bore. The absolutely last stage when machining the hub is the finishing operation of the bore, which in this case is performed in another machine.

Troubleshooting

This section covers the most common challenges within railway wheel turning and how to solve them. Typical challenges are:

- Chip control
- Insert wear
- Bad surface finish due to vibration
- Tool holder breakage

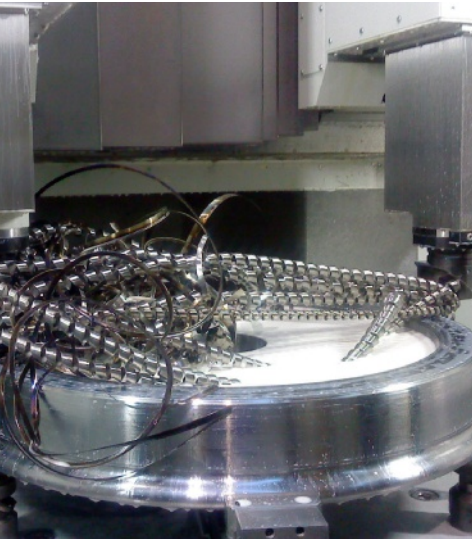

Chip control

CHALLENGE

In the web profile operation long contact length may lead to bad chip breaking (long chips).

SOLUTION - MODIFY FEED RATE

- Adjust the feed rate to the geometry in use

CHALLENGE

Too much amount of raw material when machining the rim puts high pressure on the insert, since a big part of the cutting edge is engaged in the cut. This creates high cutting forces and vibration which in some cases leads to insert breakage.

SOLUTION - RE-PROGRAMMING

Re-program for a "roll in" operation to take out the extra amount of stock (1), before making the final complete cut (2).

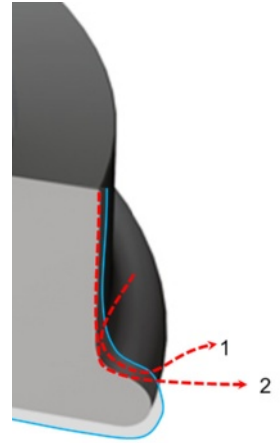

Insert wear

CHALLENGE

Insert breakage is often described as a problem, but is normally the result of plastic deformation or thermal cracks on the insert.

SOLUTION

- If thermal cracks: Increase the coolant flow as much as possible and ensure that the jet is directed correctly: hitting the insert
- If plastic deformation: Modify feed rate and use a more heat resistant grade (P25 → P15 → K15)
- Change to a more heat-resistant grade

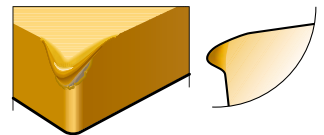

Plastic deformation

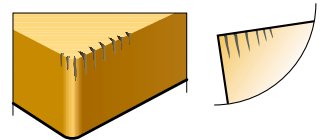

Thermal cracks

Bad surface finish due to vibration

CHALLENGE

Bad surface finish is caused by vibration and typically occurs on the web and hub.

SOLUTION

- Check the clamping of the insert
- Try to improve the stability of the tool
- Use a bigger shank size, shorter shank overhang and bigger Coromant Capto holder (check that the pull-in force is correct)
- Re-program so the feed is in the direction towards the wheel clamping, pushing the wheel downwards
- Decrease speed or/and increase feed
- Change to smaller insert or nose radius

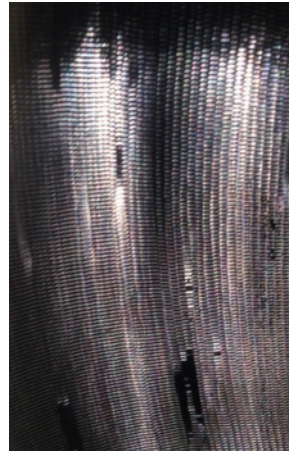
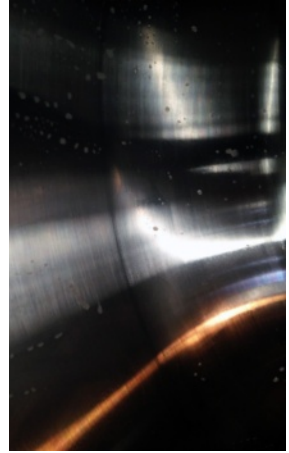

Tool holder breakage

CHALLENGE

If tool holder breakage occurs it can be caused by several different reasons:

- Insert breakage
- Overload due to too much stock of material
- Too high cutting depth
- Worn out insert pockets

SOLUTION

If the problem is worn out insert pockets: Establishing a routine for tool maintenance in the workshop will prevent problems and save a lot of money.



- Torque wrench
- To get the best performance out of each insert clamping system, a torque wrench should be used to correctly tighten the insert
- See laser marking on each tool holder or the Main catalogue/ Turning tools for the correct insert tightening torque (Nm)



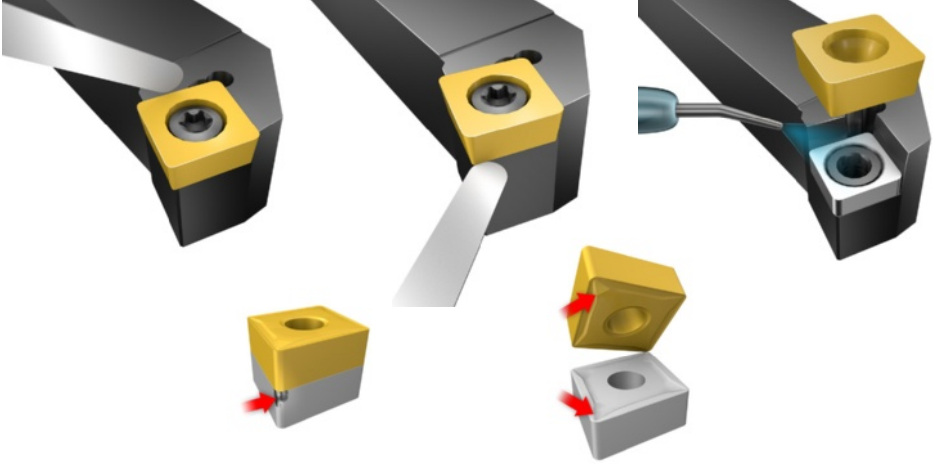

- Insert seat
 - It is important to ensure that the insert seat has not been damaged during machining or handling

Clean the insert seat: Make sure that the insert seat is free from dust or chips from the machining. If necessary, clean the insert seat with compressed air.

RE-TURNING RAILWAY WHEELS

Initial considerations

When re-turning it is desirable to choose a cutting depth which is as large as possible in order to achieve short machining times. This is however highly depending on the wear conditions of the predominant part of the worn wheel.

When choosing tools and inserts, consider the following:

- What type of wheel to be re-turned
- The wear condition of the predominant part of the worn wheel
- Machine power that is available
- In certain cases the profile can be turned in one single pass. With other machines and other circumstances it may be necessary to divide the machining into several stages in order to produce the right profile and diameter dimensions for the wheel

Dividing the machining into several stages is common in underfloor machines where friction force is used to drive the wheel.



When re-turning?

How often the wheels are being re-turned depends on how the wheel sets are used. You re-turn high speed trains more frequently for security and comfort reasons than compared to freight train wheels. But on the other hand, for these freight wheels, when machined the cutting depths are much deeper.

- Freight: Re-turning not very often (every 5–10 year)
- Regional train / Metro: Re-turning at least once a year
- High speed: Re-turning frequently, every 5-8 wek, (every 90-100.000 km)

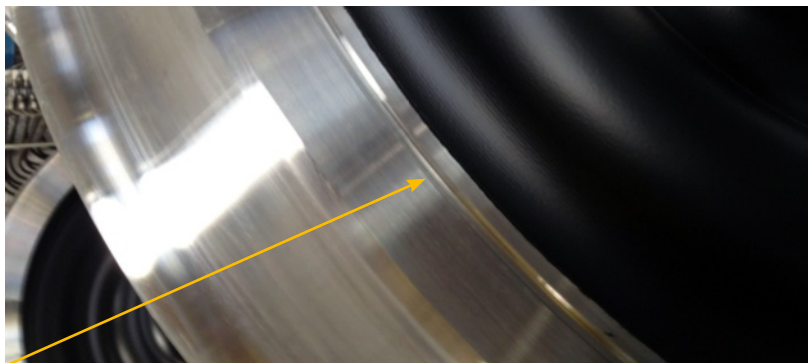

To avoid risking machining outside the hardened zone, the minimum diameter usually is marked with a groove on the outer diameter. When the groove is missing, this needs to be measured instead.

Machine types

When re-turning railway wheels it is always dry machining. Depending on train type there are different demands on the machine type, deciding whether to use a underfloor or overfloor machine. There are also other less common machine alternatives, but they will not be further discussed in this guide.

UNDERFLOOR

- Metro/ Passenger trains (wagons and cars are fixed together)
- Locomotives
- High speed

OVERFLOOR

- Freight
- Passenger cars (cars can be separated)

OTHERS CONCEPTS

- Portable machine
 - Normally rented and used in the workshop
 - Is to be found at private maintenance companies



Cars



Trains

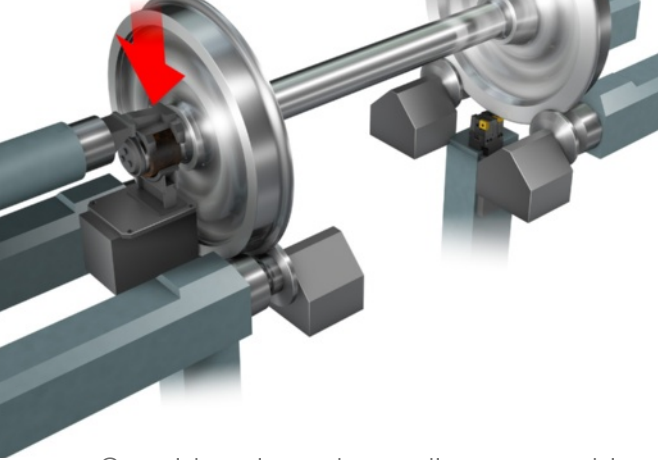

Considerations depending on machine type

UNDERFLOOR MACHINE

In this machine you re-machine profiles of locomotives, high speed trains and metro trains.

Clamping characteristics

- Hydraulic cylinders load on axle bearings

Limitations

- Maximum cutting depth

Clamping method

The wheel set in operation is lifted up and driven by four conical rolls on periphery. To increase the force on the friction drive the latest solution is to add hydraulic cylinders load on axle bearings.



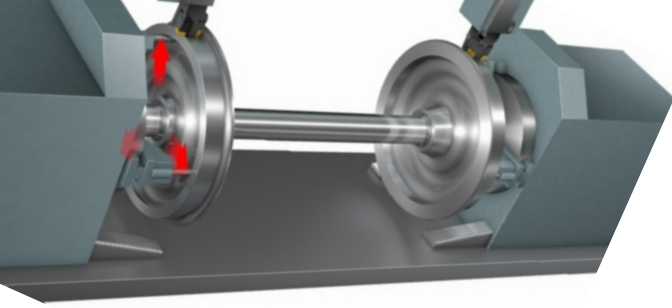

Overfloor machine

In this machine you mainly re-machine freight trains and passenger car wheels. There are two different ways to clamp the wheel: one old and one more modern method.

OLD CLAMPING

Clamping characteristics

- Wheel sets, meaning axle- and wheel discs are separated from the vehicle

Limitations

- Deformation of wheel (inner diameter)

Clamping method

- Wheel sets, meaning axle- and wheel discs are separated from the vehicle (dismounted from locomotive or train)
- Axle is fixed by two centre sleeves from left and right side on centre bores. To drive the wheel set a chuck is clamping the inner diameter of the wheel flange. Alternatively friction drive
- There are always damages on the inner diameter of the wheel (deformation)



Modern clamping method

In this type of machines mainly freight car wheels are re-machined. Freight car wheels are normally hard worn out, therefore a bigger depth of cut is needed to achieve correct profile.

Clamping characteristics

- Rigid clamping needed: To reach this big depth of cut (up to 12 mm) we need a rigid clamp that allows to handle the high cutting forces

Limitations

- Long chips may cause problems with the clamping devices and hydraulic hoses



Portable machine

This type of machine is normally rented and used in the workshop. A cheap use-on-demand alternative.

- To be found at private maintenance companies
- There are also a portable machine type to bring out on the rail

Clamping

- Like underfloor machine, but less stable / less friction conditions
- Lower cutting data



MobiTurn/ Hegenscheidt

PRODUCT AND WHEEL OVERVIEW

Wheel overview

The rim is the part of the wheel that is in contact with the rail, hence the part that needs to be re-turned. The rim is divided into three areas:

1. Outside
2. Contact surface
3. Flange

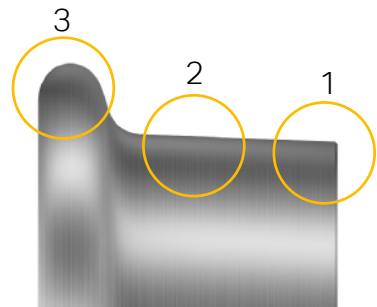
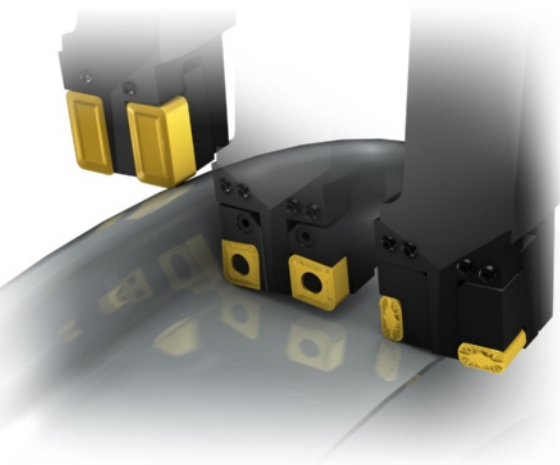

Product overview

TOOL HOLDERS AND INSERTS

There are T-Max P® tool holders optimized for machining railway wheels. Inserts are available in different steel grades and geometries for roughing to finishing.

Note: Remember to always look for the latest assortment on our website www.sandvik.coromant.com. Special offer for railway turning is available, for more information contact your local Sandvik Coromant representative.

Tool holding



Shanks for cartridges

Inserts





- Size 19, 30 and 32 mm
- Grades GC4325 and GC4215
- Geometries for roughing to finishing (-PR, -PM, -PF)

GRADES FOR RAILWAY WHEEL RE-TURNING

In this table you find grade recommendations depending on the conditions of the wheel.

The choice of cutting speed is always a combination of the type of grade you choose to work with and the condition of the wheel. In general, it is recommended to choose a lower cutting speed when turning hard wheels with brake plates and similar, and a higher cutting speed when turning softer wheels in better condition.

	ISO P	Wheel condition
Less worn 	GC3015	Wheel condition 1: Wheels with less worn out profiles are machined with higher cutting data for maximum productivity. Use the harder grade GC3015.
	GC4215	Wheel condition 2: The majority of worn out wheels with some flat spots, over rolled rim or thermal cracks are machined with the overall first choice grade GC4215.
	GC4325	Wheel condition 3: Wheels with heavier damage as well as low speed machines that require a tougher tool shall be machined with grade GC4325.
Badly worn	SH	Wheel condition 4: Badly damaged wheels are machined at low cutting speed. Use the uncoated grade SH.

Note: All the insert grades are available in most common sizes and styles in the standard assortment. More options are available as standard.

SITUATION ANALYSIS

The main purpose with the situation analysis is to ensure we have stability. Depending on if it is a underfloor or overfloor machine there are different things to consider:

- L-style inserts don't have shims. Look at the insert, cartridge and basic holder for damages (the heat makes it become blue)
- Cartridge (protecting the basic holder)
- Overheated, broken insert
- Plastic deformation, breakages
- Basic holder, which usually is special

Considerations

OVERFLOOR MACHINE

- Cutting depths
 - Rigid clamping enables machining with high cutting depths
 - Normally more than one pass is needed – for surface finishing and adjustments of the dimensions
- Choice of inserts
 - Different insert grades can take different depths of cut (see table on page 36)

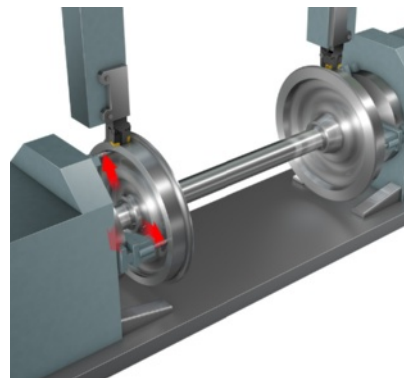

UNDERFLOOR MACHINE

- Chip breaking
 - Good chip breaking is a matter of security for the operator and also for the machine
 - If long chips it will damage cables and hydraulic tubes, if rapped around the axes they are difficult and dangerous to remove
- Cutting depths
 - Reduced cutting depths are recommended to avoid too high cutting forces

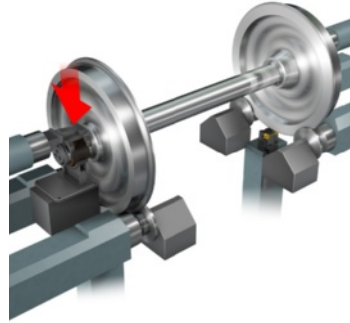

Typical wear conditions

1. Outside

The machining starts from here. Wear on this part occurs normally only on freight cars in the shape of over rolled material putting high demands on the tools in terms of intermittence and hardness. The hardness can be up to 45 HRC and has to be machined with reduced cutting data.

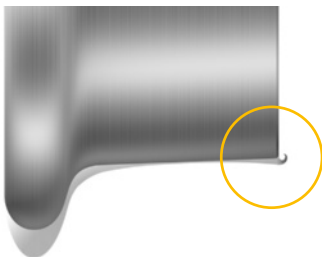

Over rolled material occurs on the outside

2. Contact surface

A typical wear are flat spots. Flat spots occur when you have blocked wheels, normally during fall due to wet leaves on the rails. This spots are very hard and can additionally lead to an interrupted cut. Flat spots, cracks and inclusions are the three most common wear types for which machining with reduced cutting depth is the step 1 solution.

Note: At modern trains this wear type is less common, thanks to electronic brake systems (ABS) and electrical power control systems.



Flat spots



Cracks



Inclusions

3. Flange

The flange is reduced in width and by reduced wheel diameter it can grow up. Dimension „h“ is normally 26 mm but it might grow up to more than 30 mm at really hard worn wheels. Sometimes it is necessary to cut off this before re-machining the profile.

Wheels harden up very often on freight cars because the brakes are on the outer diameter of wheels. If the brakes are used very often (routes in the mountains) the wheels heat up and cool down. This increases the surface hardness of the wheels.

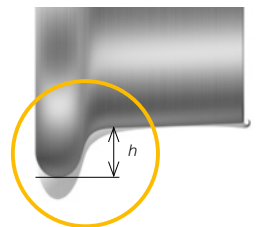

Deformation on the flange

TYPICAL WEAR CONDITIONS AND SOLUTIONS

Wear condition	1. Outside	2. Contact surface	3. Flange
Freight	Over rolled	Hardened (flat spots) occur when the train brakes	Profile deformation friction of the track.
Metro	NA	Inclusions (from stones on the rail). Hardened (flat spots) occurs when the train brakes.	Profile deformation friction of the track.
High speed	NA	Hardened (flat spots) occurs when the train brakes. Cracks. But since they re-turn more often than the freight wheels not as often and less.	Some friction marks can occur when the flange touches the track.
Solution step 1	Decrease feed and speed.	Machine with a cutting depth (ap) below the flat spot or crack.	See best practice, page 42.
Solution step 2	SH grade is first choice. Speed down to 10– 20 m/min, Use a stable geometry (-PM or -22) that will support the edge. Try to undercut this parts if possible.		NA

BEST PRACTICE

Underfloor machine

In the following pages you find best practice for how to re-turn a railway wheel made of rolled steel.

MACHINING AT NORMAL CONDITIONS

When low cutting depths the C-style inserts is the first choice. These inserts give good chip breaking and chip control when machining the flange due to the entering angle. First choice grade is GC4215.

Note: These tools are sometimes also applicable in overfloor machines when no need for large ap.

Tools in use

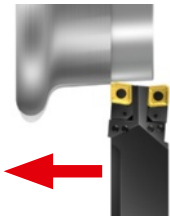

Tool holder: R175.33-5055
Cutting unit: R175.32-3223-1911
Insert: CNMX 19 11 40 -PF

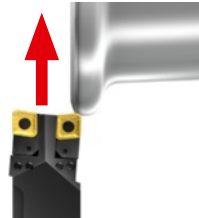

Tool holder: R175.33-5055
Cutting unit: R177.32-3219-1911
Insert: CNMX 19 11 40 -PF

Cutting data

v_c m/min (ft/min)	f_n mm/rev (in/min)
70-80 (230-300)	0.5-1.5 (0.02-0.059)

MACHINING AT SEVERE CONDITIONS - BADLY DAMAGED WHEELS

When machining a badly damaged rim normally you need to reduce the cutting speed by half. You also need to adjust the feed to the cutting conditions.

Tools in use

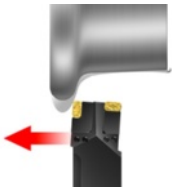

Tool holder: R175.32-5055M
Cutting unit: R175.32-3223-19
Insert: LNMX 19 19 40 -PM

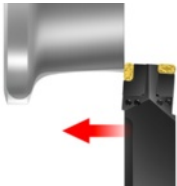

Tool holder: R175.32-5055M
Cutting unit: R175.32-3223-19
Insert: LNMX 19 19 40 -PM

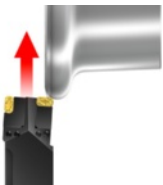

Tool holder: R175.32-5055M
Cutting unit: R177.32-3219-19
Insert: LNMX 19 19 40 -PM

Cutting data

v_c m/min (ft/min)	f_n mm /rev (in/min)
70-80 (230-300)	0.5-1.5 (0.02-0.059)

Overfloor machine

SEVERE CONDITIONS - BADLY DAMAGED WHEELS

Machining the long flange – alternative 1

This is one example of re-turning of a worn wheel with skid flats, shelled tread or thermal cracks. If stable clamping and a machine with enough power you can take the flange and the contact surface in the same step.

Tools in use



Tool holder: R175.32-5055M
Cutting unit: R175.32-3223-30
Insert: LNMX 30 19 40 -PR

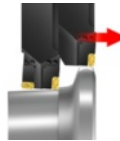

Tool holder: R175.32-5047M
Cutting unit: R175.32-3223-30
Insert: LNMX 30 19 40 -PR

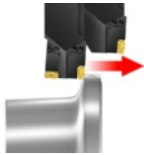

Tool holder: R175.32-5055M
Cutting unit: R175.32-3223-30
Insert: LNMX 30 19 40 -PR

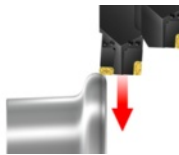

Tool holder: R175.32-5055M
Cutting unit: R177.32-3219-19
Insert: LNMX 19 19 40 -PR

Cutting data

Cutting speed v_c m/min (ft/min)	Feed f_n mm/rev(in/rev)
40 (130)	0.3-1.5 (0.012-0.059)

OPTIMIZATION

- For increased tool life: change to a more heat-resistant grade (see the grade recommendation table, page 36)

Machining the long flange – alternative 2

If the clamping is unstable and the machine have insufficient power this is an alternative way of machining the flange. You make a rough cut of the flange in the first step. In the next step you machine the contact surface and finish the flange.

Tools in use

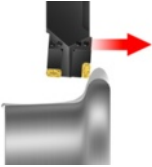

Tool holder: R175.32-5055M
Cutting unit: R175.32-3223-30
Insert: LNMX 30 19 40 -PM



Tool holder: R175.32-5055M
Cutting unit: R175.32-3223-30
Insert: LNMX 19 19 40 -PM

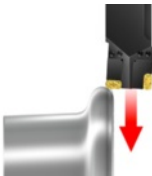

Tool holder: R175.32-5055M
Cutting unit: R177.32-3219-19
Insert: LNMX 19 19 40 -PM

Cutting data

Cutting speed v_c m/min (ft/min)	Feed f_n mm/rev(in/rev)
40 (130)	0.3-1.5 (0.012-0.059)

OPTIMIZATION

For increased chip breaking LNUX –PF, CNMX –PF

SH is an alternative grade for really bad damaged wheels

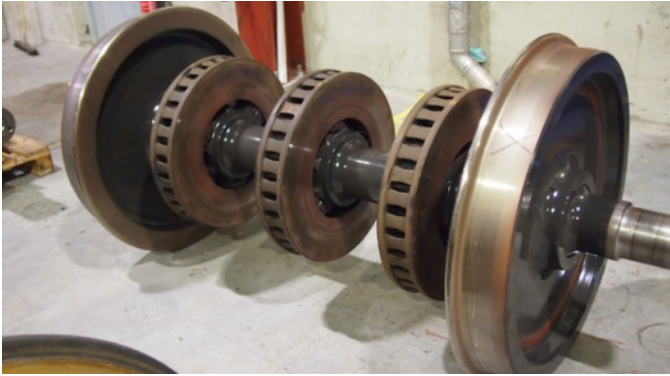

The brake disc

A typical component you will find under the trains is the brake disc. The brake disc is machined on demand using two tools mounted on a separate device on the machine. For this machining, we recommend using Sandvik Coromant's special offer of tool holders (length 130 mm) in combination with standard D-style wiper inserts (-WMX). This combination works excellent at low depths of cut and high speeds giving good chip control. The D-style inserts are also good for clearance between the brake discs.

TROUBLESHOOTING

Typical challenges when re-turning wheels are:

- Insert breakage
- Short hot chips
- Vibration due to worn out cartridge

Insert breakage

CHALLENGE

Insert breakage makes the carbide stick into the wheel.

MAIN CAUSE

- Overloaded insert
- Hard spots, cracks or flats spots on the wheel

SOLUTION

- Inspect the insert in time to avoid breakage
- Reduce feed and speed drastically and then slowly try to increase it
- Gently try to remove it (or grind it out)

Note: Occurs in both under- and overfloor machines.



Flat spots



Vibration due to worn out cartridge or lever clamp

CHALLENGE

- Compression marks on the cartridge leading to vibration

MAIN CAUSE

- Big forces on the insert geometry cause these compression marks
- Insert movement due to incorrect clamping forces

SOLUTION

- Check and change cartridge more frequently
- Check the lever clamp for damage

Hot chips (finishing operation)

CHALLENGE

- Hot chips on the machine and component will heat up the machine. They can also hit the operator

SOLUTION

- Make sure the chips are evacuated safely from the machine
- Reduce the feed, reduce the speed or change to a medium geometry, -PM

Note: Occurs in underfloor machines only.





Too high cutting forces due to too high feed rate

CHALLENGE

- Too high feed rate causes higher cutting forces than the created friction drive. This makes the wheel stop which often leads to insert breakage, deep cuts on the wheel and sometimes piece from the insert getting stuck in the wheel

SOLUTION

- Use an adequate feed rate
- Use another insert with a cutting depth that cuts off enough material to remove the remainings of the broken insert with a very low feed
- Sometimes more extreme methods might be necessary, using a tool for grinding

Note: Occurs in underfloor machines only.

