

Handling instructions For dampened HSK adaptors



● ● ● ● **SilentTools®**



www.sandvik.coromant.com/HSK

Head office:
AB Sandvik Coromant
SE-811 81 Sandviken, Sweden
www.sandvik.coromant.com
E-mail: info.coromant@sandvik.com

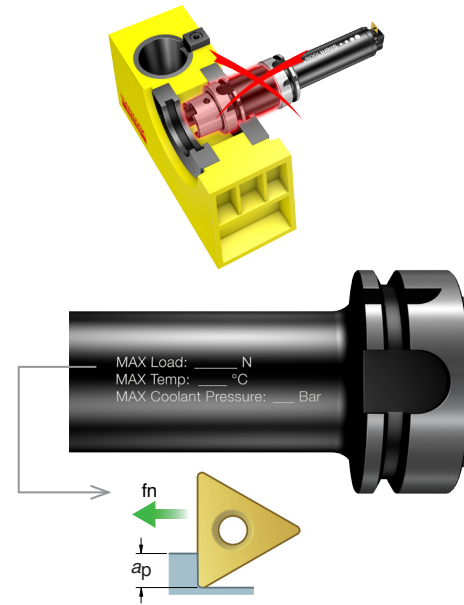
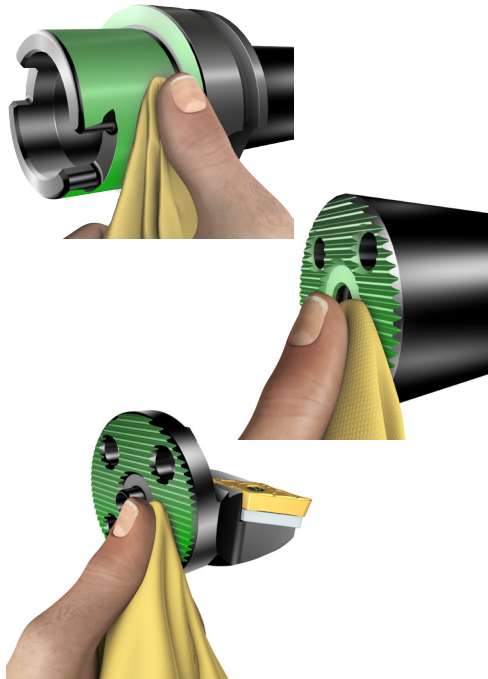
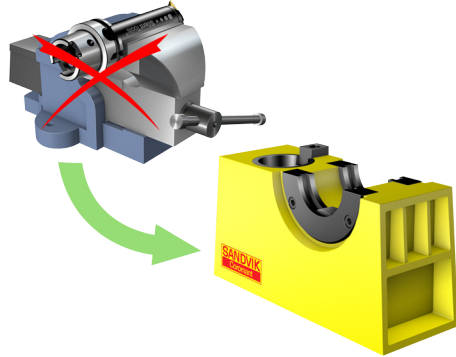
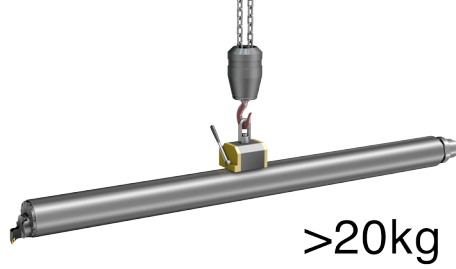

www.sandvik.coromant.com/silenttools/calculations

Tool name	ISO Code	ISO Code (inch)	ISO Code (inch) head length	ISO Code (inch) tool length	ISO Code (inch) tool length	ISO Code (inch) tool length	ISO Code (inch) tool length	ISO Code (inch) tool length	ISO Code (inch) tool length	ISO Code (inch) tool length	ISO Code (inch) tool length
Find a turning tool for your deep hole machining											
Find by hole parameters											
Find by Adatik Code											
Actual code											
Estimated tool definition											
ISO code											
ISO code											
ISO code											
ISO code											
ISO code											
ISO code											



Ø	Tool name	Nm (Lb)
Ø16	B18,3/1960-5UNFX3/8-12,9	2,8 (2,1)
Ø20	B18,3/1960-6UNFX3/8-12,9	4,0 (3,0)
Ø25	M4X12-12,9	5,0 (3,7)
Ø32	M5X12-12,9	9,0 (6,6)
Ø40, Ø50, Ø60	M6X12-12,9	15 (11)

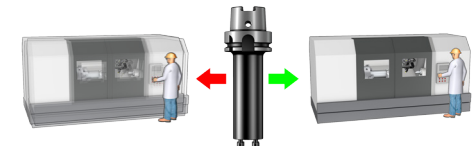
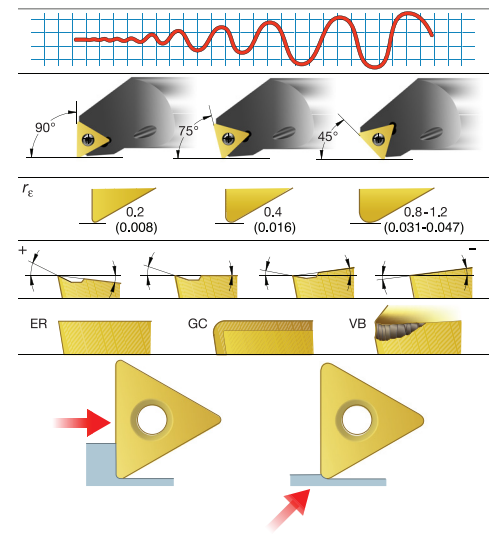

Silent Tools™ Application guide
www.sandvik.coromant.com