



**SANDVIK**  
Coromant

Face and shoulder milling

# M5R90 aluminium cutter

Developed for the automotive industry, M5R90 is a robust, lightweight and stable cutter that produces a predictable surface finish.



# M5R90 – a new concept for face and shoulder milling

M5R90 is the first choice for roughing to semi-finishing in shoulder milling operations of automotive aluminium components such as cylinder blocks, cylinder heads and transmission housing.

## The cutter

The cutter works with adjustable PCD cartridges and supports a depth of cut of up to 8 mm (0.315 inch) with a 0.4 or 0.8 mm (0.016 or 0.031 inch) radius depending on the cartridge used.

An internal system directs coolant from the spindle to the cutting edge, ensuring an effective cooling effect and cleaning action.



## Features and benefits

- The cutter body is produced in a special aluminium alloy combining low weight with high toughness
- High density cutter is balanced with 10 000 rpm in a G2.5 class. This allows it to run at high speed without compromising the machine spindles
- The PCD tips are brazed in a steel cartridge which allows axial adjustments
- The PCD tips can be reground up to three times, ensuring prolonged tool life
- Several cutting edge geometries are available

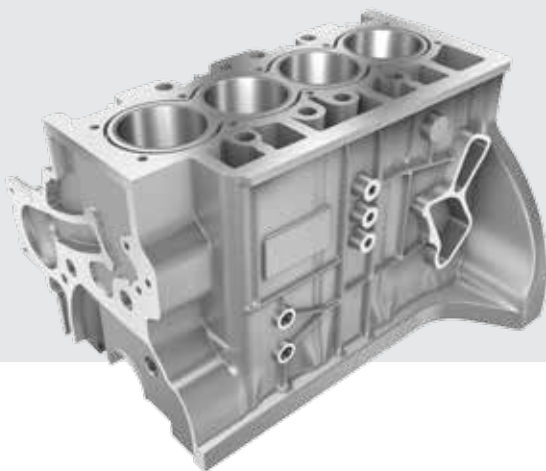

For more information contact your local Sandvik Coromant representative or visit [www.sandvik.coromant.com](http://www.sandvik.coromant.com)

Head office:  
AB Sandvik Coromant  
SE-811 81 Sandviken, Sweden  
E-mail: [info.coromant@sandvik.com](mailto:info.coromant@sandvik.com)  
[www.sandvik.coromant.com](http://www.sandvik.coromant.com)

C-1040:218 en-GB © AB Sandvik Coromant 2018

**SANDVIK**  
Coromant